



Contents lists available at SciVerse ScienceDirect

Cancer Letters

journal homepage: www.elsevier.com/locate/canlet



Mini-review

CD146, a multi-functional molecule beyond adhesion

Q1 Zhaoqing Wang*, Xiyun Yan*

Protein and Peptide Pharmaceutical Laboratory, Institute of Biophysics, Chinese Academy of Sciences, 15 Datun Road, Chaoyang District, Beijing 100101, People's Republic of China

ARTICLE INFO

Q2 Article history:
Received 8 October 2012
Received in revised form 13 November 2012
Accepted 28 November 2012
Available online xxxxx

Keywords:
CD146
CAM
Adhesion
Angiogenesis
Cancer therapy

ABSTRACT

CD146 is an epithelial cell adhesion molecule that was originally identified as a tumor marker for melanoma (MCAM), due to its over-expression on fast proliferating cancers. However, recent evidence reveals more roles for CD146, including miscellaneous processes such as development, signaling, cell migration, mesenchymal stem cells differentiation, angiogenesis, and immune response, besides cell adhesion. CD146 has increasingly become an important molecule, especially identified as a novel bio-marker for angiogenesis and a promising target for cancer therapy. Here we have reviewed the dynamic research of CD146, particularly newly identified functions and the underlying mechanisms of CD146.

© 2012 Elsevier Ireland Ltd. All rights reserved.

1. Introduction

CD146 (cluster of differentiation 146) is a cell adhesion molecule (CAM) and belongs to the immunoglobulin superfamily (IgSF) [1]. CAMs are proteins located on the cell surface involved in the process of cell adhesion through the binding with other cells or with the extracellular matrix (ECM). Cell adhesion is a fundamental process required for the correct functioning of multicellular organisms. CAMs are involved in an extensive range of physiological processes, including cell–cell and cell–matrix interactions, cell migration, cell cycle, and signaling as well as morphogenesis during development and tissue regeneration. Increasing evidence highlights the fundamental role of CAMs in a variety of pathological progressions, such as cancer, inflammation, pathogenic infections, and autoimmune disease [2].

Johnson and colleagues are discoverers of CD146. In 1987, they reported that CD146 was expressed most strongly on metastatic lesions and advanced primary tumors and was only rarely detected in benign lesions [1]. CD146 is an integral membrane glycoprotein of 113 kDa, whose sequence of amino acids (AA) consists of a signal peptide, an extracellular fragment structure of V–V–C2–C2–C2 with five immunoglobulin-like domains, a transmembrane region and a short cytoplasmic tail [3,4]. Subsequently, CD146 genome localization and organization, promoter structure [5], and the expression pattern in both human normal and malignant tissues [6] were reported by Johnson's laboratory. Most interestingly, CD146 presents on the endothelia of blood vessels penetrating primary and metastatic melanomas, plays critical role in tumor angiogenesis and hematogenous spread, providing the first evidence for the mechanism underlying CD146-mediated tumor metastasis [7].

CD146 is a specific antigen in human malignant melanoma has also been confirmed simultaneously by another independent research group [8,9]. Growing evidence has demonstrated that CD146 is overly expressed on a variety of carcinomas in addition to melanoma. Based on this attribute, CD146 attracts a plethora of attention, and therefore becomes an almost certain potential marker for tumor diagnosis, prognosis and treatment [7,10,11]. The majority of studies (50% more) about CD146 have focused on the observation of its role in varied processes of cancers, through down-regulation of CD146 expression via *in vitro* knockdown or *in vivo* inhibition in xenografted tumors in mice [11]. Over the past decades, precise details, especially concerning CD146 functions in various cancers, have been documented and further summarized

Abbreviations: CD146, cluster of differentiation 146; CAM, cell adhesion molecule; IgSF, immunoglobulin superfamily; AA, amino acid; ECM, extracellular matrix; CD146-l, long form of CD146; CD146-s, short form of CD146; sCD146-l, soluble form of CD146; Mel-CAM, melanoma CAM; MCAM, melanoma CAM; MET-CAM, metastasis CAM; HEMCAM, hemopoietic CAM; PKC, protein kinases C; V set, variable region; C-2 set, constant region; NOF, neurite outgrowth factor; TGF-β, transforming growth factor-beta; NGF, nerve growth factor; ET-1, endothelin-1; MSCs, mesenchymal stem cells; mAb, mouse antibody; NK cell, natural killer cell; VEGF, vascular endothelial growth factor; VEGFR, vascular endothelial growth factor receptor; TNF-α, tumor necrosis factor-alpha; IL, interleukin; EMT, epithelial–mesenchymal transition; Th cells, T helper cells; NF-κB, nuclear factor-kappa B.

* Corresponding author. Tel.: +86 010 64888583; fax: +86 010 64888584.

E-mail addresses: clairezqwang@hotmail.com (Z. Wang), yanxy@ibp.ac.cn (X. Yan).

in many reviews. Most of reports support the notion that CD146 promotes tumor growth, angiogenesis, and metastasis, and regard CD146 as a promising target for tumor therapy [4,7,10–14]. Therapeutic strategies targeting CD146 include humanized antibody [15–17] and vaccination [18,19].

Contrast with the wide expression pattern of most other CAMs in normal tissues, the CD146 expression is restricted to limited adult normal tissues. However, its expression is broadly and highly detected in embryonic tissues. Recent investigations have revealed more multi-functional role for CD146, not merely limited to cell adhesion but expanded to processes such as development, signaling, cell migration and motility, proliferation, differentiation, and immune response. We will discuss the various newly identified functions of CD146 in physiological and pathological processes with the aim to update and present the knowledge about CD146.

2. The nomenclature of CD146

Human CD146 has been previously designated as different synonyms, including MUC18, A32 antigen, S-Endo-1, MCAM (melanoma CAM), Mel-CAM (melanoma CAM), MET-CAM (metastasis CAM) and HEMCAM (hemopoietic CAM), by several independent laboratories. Lehmann et al. originally discovered CD146 with a monoclonal antibody (mAb) of MUC18, which specifically reacted with human malignant cells but not with benign cells of melanocytic lineage, and thus designate this antigen as MUC18 [1,3]. Coincidentally, Shih et al. [8,9] identified the same molecule (MUC18) with a mAb A32 as a human melanoma-associated antigen with gradually increasing expression as tumors acquired metastatic potential, and named this antigen (CD146) as A32. Bardin et al. named CD146 as S-Endo-1 because this antigen constitutively expressed in all types of human endothelial cells [20]. Due to the characteristic of CD146 as an integral membrane CAM and a specific melanoma antigen, it was named as MCAM (melanoma cell adhesion molecule) [8] or Mel-CAM [21,22]. Recently, according to the critical role of CD146 on modulating tumor metastasis, Wu et al. endows CD146 another alias, MET-CAM [23].

The avian homologue of CD146, was initially discovered as the receptor of neurite outgrowth factor (NOF) in the development of the retina [24] and was named as Gicerin [25]. It has been revealed that the avian CD146 is enriched in hemopoietic progenitors of

embryonic bone marrow, and promotes thymus homing of pro-T cells. Therefore, the avian CD146 is also called HEMCAM [26].

3. The structure of CD146 gene

The exon–intron structure of CD146 genes from divergent examined species, i.e., human [5], mouse [27] and chicken [26], is similar. The full-length mRNA consists of 16 exons. The first exon of hCD146 (human CD146) encodes the 26-bp of 5'-UTR region and more than one-third of the signal leading peptide in the premature hCD146 polypeptide sequence. The first V (variable region) set and three C-2 (constant region) sets are each encoded by two exons. The second V set is encoded by three exons. The sixteenth exon contains a more than 1 kb 5'-UTR region. Interestingly, introns of the fifth and the fifteenth contain a consensus poly (A) signal; in another words, CD146 gene contains three poly (A) signals (Fig. 1A) [5]. The TATA- and CAAT-box-less core promoter of hCD146 starts from about 505-bp upstream of the first ATG, is GC-rich and encompasses several consensus binding motifs recognized by transcription factors SP1, AP-2, and CREB [28,29]. Because transcription factor AP-2 is crucial in an embryonic development, multiple AP-2 binding sites in the CD146 promoter region imply that CD146 may be up-regulated during development through AP-2-mediated regulation at transcriptional level (Fig. 1B).

Analysis of mouse CD146 gene structure revealed that a selective mRNA splicing occurred within the fifteenth exon; generating a mCD146-s (mouse CD146-short) [27]. The high similarity of CD146 genes structure among divergent species and the existence of three consensus poly (A) signal in the human and mouse CD146 genes, imply alternative mRNA splicing transcription of human CD146 may occur as same as its orthologous gene of mouse CD146. Thus, there is an urgent need to address whether or not alternative mRNA splicing transcript of hCD146-s (human CD146-short) is existed.

4. CD146 protein

CD146 homologous proteins exhibit high sequence identical among divergent species, including human [1,3], mouse [30,31], rat [32,33], chicken [25,26] and zebrafish [34]. The mature CD146 is composed of an extracellular fragment, a single

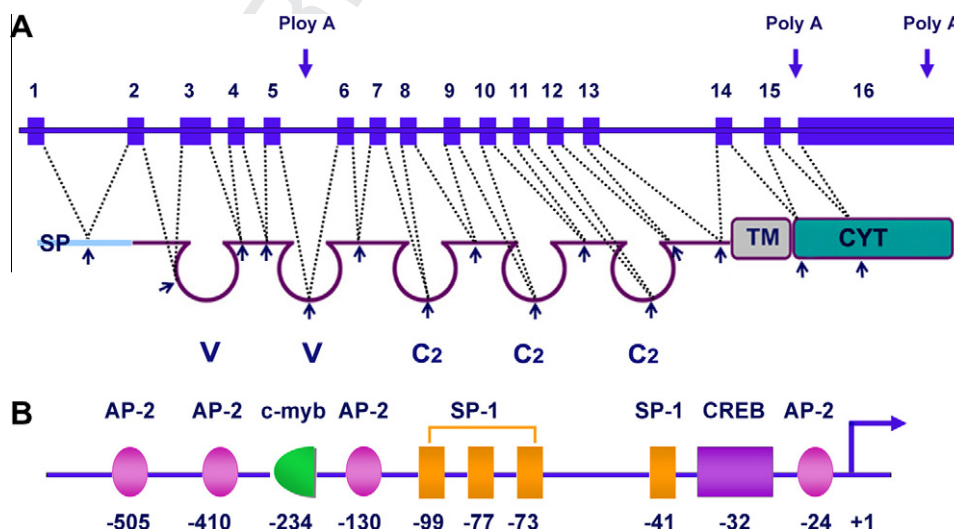

Fig. 1. Protein structure and isoforms of CD146. (A) Protein structure of human, mouse, and chicken CD146. V, variable Ig-like domain; C-2, constant Ig-like domain; TM, transmembrane domain; CYT, cytoplasmic domain; wiggled line, conserved N-glycosylation site. (B) The sequence similarity among human, mouse, and chicken CD146 protein. (C) Three isoforms of chicken CD146 protein.

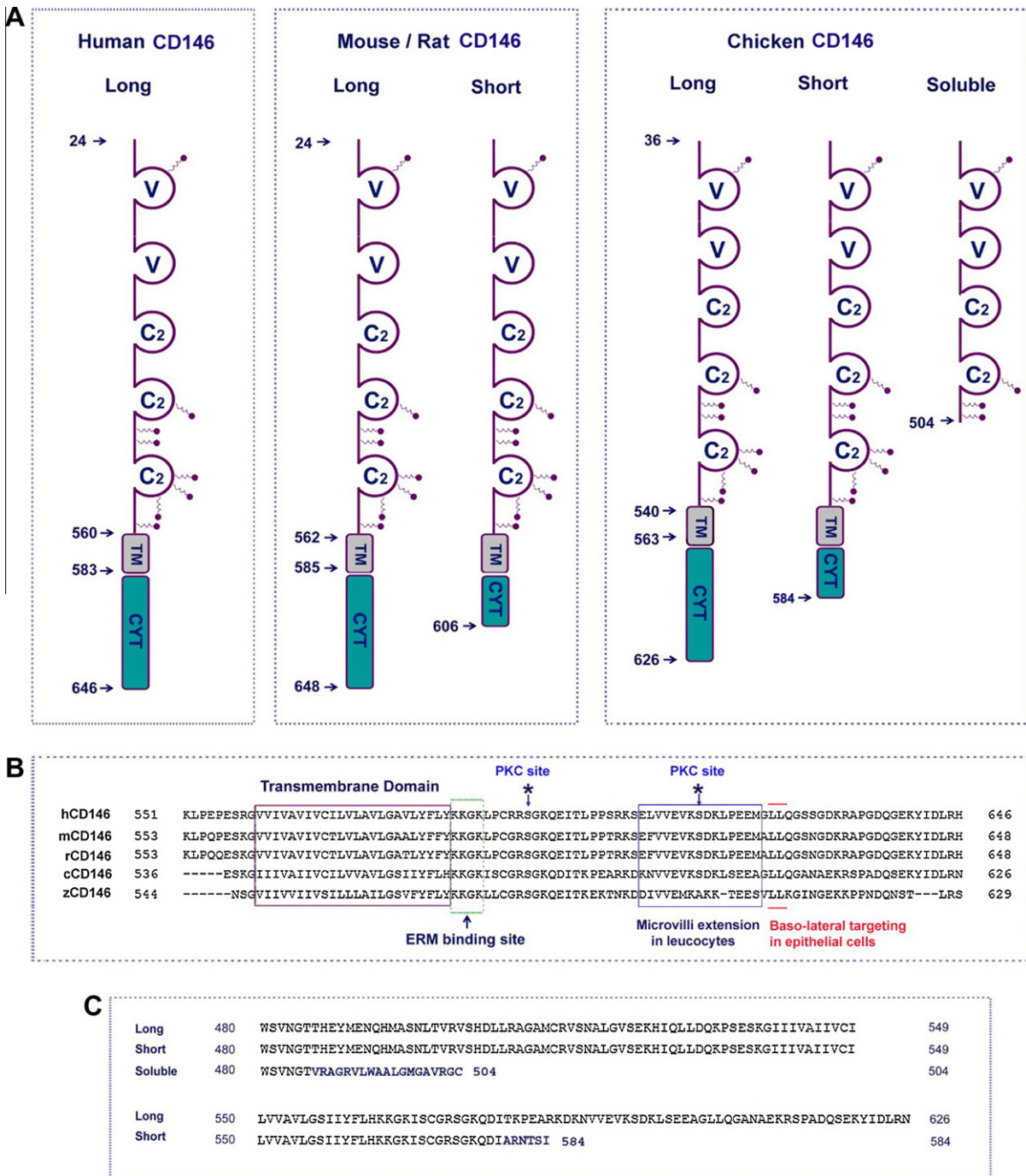

Fig. 2. Schematic representation of the exon-intron and promoter structure of the CD146 gene. (A) Exon-intron structure and the coding domains. Exons are presented by the filled boxes; introns are shown by lines. SP, signal peptide; V, variable region Ig-like domain; C-2, constant Ig-like domain; TM, transmembrane domain; CYT, cytoplasmic domain; (B) Promoter transcriptional regulatory motifs. AP-2, c-myc, Sp1 and CREB binding sites, are indicated by the position of the 5' end of each site distant from the transcription start site.

trans-membrane region and a cytoplasmic tail [1,3]. A structure of V-V-C2-C2 Ig-like domain and 8 putative N-glycosylation sites are present in the extracellular fragment across species [26] (Fig. 2A). The premature CD146 has a signal peptide located on the anterior region of the amino terminal. The cytoplasmic domain contains two potential recognition sites for protein kinases C (PKC), an ERM (protein complex of ezrin, radixin and moesin) binding site, a motif with microvilli extension and a double leucine motif for baso-lateral targeting in epithelia (Fig. 2B).

4.1. CD146 isoforms

CD146-l (long form) has been reported in all of species. CD146-s (short form) was found in species of mouse [27], canine [35] and avian [36]. The soluble form of sCD146 was examined in human [37,38] and in chicken [26]. Long and short isoforms of CD146 have same extracellular and transmembrane domains; differ by their cytoplasmic tails. The AA composition of cytoplasmic tails is fully disparate between each other, e.g., the big difference is found in avian CD146-l and CD146-s. At the cytoplasmic domain, CD146-l

has two protein kinase C (PKC) phosphorylation sites; whereas CD146-s has only one PKC site. Soluble CD146 (sCD146) lacks both transmembrane and cytoplasmic regions. Using NH₂-terminal peptide sequencing, the AA composition of avian sCD146 was confirmed (Fig. 1C) [26].

Avian sCD146 shows similar homophilic adhesion activity with its CD146-l and CD146-s, CD146-s and CD146-l have different function. Regarding their cytoskeleton remodeling activity, canine CD146-l, but not CD146-s, is capable of functioning in CD146-actin cytoskeleton interaction and microvilli induction for ensuring epithelium morphogenesis, its single dileucine motif (41–42) and the serine 32 residue of the cytoplasmic domain is required for this capability [35]. The above phenomenon was explained by the study from avian CD146-l; its amino acids of 16–39 show to be involved in the extension of microvilli [32]. Avian short form of CD146 exhibits stronger activities of homophilic and heterophilic adhesion than the CD146-l [26], because the cytoplasmic domain of avian CD146-l was only involved in regulation of its activities, but not was essential for its optimal adhesive activities [36,39].

4.2. Origin of CD146 isoforms

In the literature, there is no controversy about the origin of CD146-s, i.e., CD146-s is derived from mRNA selective splicing in all of examined species other than human. However, the reported origin of CD146s (soluble form of CD146) is controversial [26,40,41]. Avian soluble CD146 detected in hemopoietic progenitors of embryonic bone marrow, is generated from mRNA splicing [26]. Human soluble CD146 detected in the supernatant of cultured endothelial cells and in the plasma of healthy subjects, is believed to be generated from shedding from membrane-embedded CD146-l [40,41]. Incubation with GM6001 inhibits the levels of sCD146 may be not sufficient for conclusion that human sCD146 is generated by shedding from CD146-l. Therefore, the contradictory origin of sCD146 should be resolved with solid evidence in the future in this field.

5. CD146 expression regulation

How CD146 expression is regulated is highly pursued in the CD146 research area. It has been gradually clear that the manner of CD146 expression regulation is different in various tissues from embryo, tumor and adult. Based on the maximal sequence similarity between CD146 with an array of neural cell adhesion molecules expressed during organogenesis, CD146 was assumed to be regulated developmentally [3]. Although the regulation manner of CD146 expression during development still remains unknown, the expression regulation manner in tumors and in adults came into prominent as following.

5.1. Epigenetic regulation of CD146 in tumors

Since the first observation that CD146 was overly expressed in melanoma compared with normal melanocyte, a growing evidence has revealed that in the growth of primary and metastatic tumors, CD146 protein levels are significantly enhanced compared with normal control samples [16]. Although numerous proteins have been proved to be aberrantly up-regulated in tumors via genetic alterations, the genetic research results indicate that increased expression levels of CD146 in tumor tissues is not due to translocation, amplification or mutation of the CD146 gene [42,43].

Recently, an inspiring epigenetic study in the literature described the first investigation about epigenetic modification of CD146 gene promoter in prostate cancer. Liu et al. indicated that CD146 was screened out from 36 candidate genes as an excellent

candidate for prostate cancer-specific methylation. The elevated expression levels of CD146 in prostate cancer were resulted from hypermethylation at the promoter of the CD146 gene. Compared with non-neoplastic prostate tissues, CD146 gene promoter was specifically methylated in prostate cancer cell lines. Conventional methylation-specific PCR technique showed greater hypermethylation of the CD146 promoter (80%, 70/88) in primary prostate cancer compared to 12.5% (3/24) in non-neoplastic prostate. Prostatic intraepithelial neoplasias and potential precursors of prostate carcinoma showed an intermediate methylation rate of 23% (7/30). Importantly, it was found that the rate of CD146 promoter methylation was directly and positively correlated with the grade of tumor stage in primary prostate carcinoma [44]. Because CD146 gene promoter is with high GC content [5], these studies employed in prostate cancer may have broad implications in other tumors. Further examination of hypermethylation of the CD146 promoter in cancers other than prostate carcinoma is expected for discovery the universal mechanism underlying CD146 overexpression in various cancers.

5.2. Inducible regulation of CD146 expression

It has been reviewed that at the adult stage, the expression of CD146 is restricted to a few tissues, such as hair follicular cells, activated T cells and intermediate trophoblast [10]. The inducible expression of CD146 by environmental signals in normal adult cells plays a major role for CD146-mediated actions in initiating proper reactions [42,43].

Some proinflammatory cytokines are able to induce CD146 expression at mRNA level, e.g., the *tumor necrosis factor*-alpha (TNF- α) and interleukin-1 α (IL-1 α) significantly induce CD146 mRNA expression in luteinizing granulosa cells [45], although this induction effect was not observed in choriocarcinoma cell line JEG3 cells [46]. In airway epithelial cells, CD146 expression is consistently up-regulated by T helper 2 cells (Th2) cytokine IL-13, and such induction in primary human bronchial epithelial cells is involved in bacterial adherence to epithelial cells [47].

Osmotic pressure also can induce CD146 expression. For example, high glucose [48], high Ca²⁺ concentration [49] and increased cAMP [21] are able to up-regulate CD146 mRNA expression in a variety of cell types. Some growth factors, such as endothelin-1 (ET-1), transforming growth factor-beta (TGF- β), and nerve growth factor (NGF) enhance the expression of CD146 mRNA in melanocytes [50], in hepatocytes [51], and in Schwann cells [52,53], respectively. In addition, crosstalk between signal pathways of protease-activated receptor 1 and platelet-activating factor receptor is able to up-regulate CD146 mRNA [54]. The above reports clearly indicate that in normal adult tissues, inducible CD146 expression play critical role in responding to environmental stimuli, such as proinflammatory cytokines, growth factor and osmotic pressure for initiating proper inflammatory reactions, cell proliferation and cellular communication.

6. CD146 and adhesion

CAMs are proteins located on the cell surface involved in the binding with other cells or with the extracellular matrix (ECM) in the process of cell adhesion. CAMs stick cells to each other and to their surroundings through interacting either with the same kind (homophilic binding) or with other CAMs, or the extracellular matrix (heterophilic binding). Four CAM families have been identified: the cadherins, the selectins, the integrins, and the immunoglobulin CAM superfamily (IgSF-CAM). CD146 belongs to the members of the Ig-CAM family, who are calcium-independent CAMs. Vainio et al. showed that the strength of CD146 adhesion

is weak in comparison to adhesion activity with selectins, integrins, and other IgSF proteins such as ICAMs, VCAM-1, and PECAM-1 [26]. CD146-adhesive properties have been investigated *in vitro* mainly through cell aggregation and solid-phase binding assays.

Taira and colleagues report that the homophilic binding of CD146–CD146 is involved in the neurite extension and neuron development [25,36,39,53,55–58]. In human cell lines, different research groups also observed that homophilic binding of CD146 is implicated in the control of cell–cell cohesion [20,59,60].

The first binding partner of CD146 reported in literature is a protein of neurite outgrowth factor (NOF), an extracellular matrix component belonging to the laminin family, found in CD146-enriched chicken embryonic retinas [24]. Later, Taira and colleagues further confirm that CD146 binds with NOF using recombinant CD146 as a probe [25]. Recently, it has been shown that Laminin-411 is a ligand of CD146 to facilitate T cells entry into the central nervous system [61]. This heterophilic binding of CD146 was also found in melanoma cell lines for mediating melanoma cell-extracellular matrix adhesion [8,59,62]. However, the identity of these cognate CD146-binding ligands has not been revealed yet.

Several lines of evidence suggest that CD146 adhesion activity is required for physiological processes. For instance, requirement of CD146-mediated adhesion is proved in trophoblast. The differentiation potential of intermediate trophoblast is positively correlated with CD146 expression levels [10,63–65]. Using our mAb of AA98 against CD146, we present direct evidence for the role of CD146 in mediating embryonic attachment and trophoblastic invasion [66,67]. We find that CD146 is specifically expressed in the receptive maternal uteri and invasive embryonic trophoblasts during the early stages of pregnancy, but it is completely absent in the non-pregnant uterus. Blocking CD146 with a function-perturbation antibody AA98 significantly inhibits the attachment of blastocysts onto the receptive uterine luminal epithelial monolayer, the trophoblastic outgrowth of blastocysts and ectoplacental cones [66,67], suggesting that CD146 adhesion activity may be varied during different developmental stages, and is required for some specific physiological processes, such as implantation.

7. CD146 and MSCs

MSCs defines a cell population of plastic-adherent multipotent mesenchymal stromal cells, comprising of a subset of cells with stem cell activity (i.e. the ability to undergo self-renewal or asymmetric cell division), which is also referred to as mesenchymal stem cells. Multipotent MSCs can differentiate into three cell types including: osteoblasts (bone cells), chondrocytes (cartilage cells), and adipocytes (fat cells). The umbilical cord MSCs have more primitive properties than other adult MSCs obtained later in life. Postnatal MSCs niche is located within the perivascular site within microvessels [68,69].

In 2007, CD146 was identified as a putative MSC marker by comparing the capacities of proliferation, differentiation, and transfection between human umbilical cord perivascular cells (HUCPVCs) and bone marrow mesenchymal stromal cells (BMSCs). HUCPVCs show a higher proliferative potential than BMSCs and are capable of osteogenic, chondrogenic, and adipogenic differentiation. Higher levels of CD146 were found to be expressed on HUCPVCs, suggesting CD146 is a MSC marker [70]. This notion was supported by the observation that CD146-positive perivascular cells show similar functional and gene-expression profiles with MSCs [71]. Therefore, the correlation between CD146 expression levels and multipotency of MSCs attracts investigations about the effects of CD146 up-regulation on phenotype of MSCs. CD146 up-regulation on highly proliferative MSCs, rendering cells capable

of trilineage differentiation [72], is linked to multipotency of trilineage potential [73]. Mesenchymal stem cells with greater differentiation potential express higher levels of CD146 on the cell surface [74]. Thus CD146 has been seen as a marker for MSCs isolated from multiple adult and fetal organs [71,72,75], suggesting that CD146 is probably actively involved in differentiation and organogenesis during development.

8. CD146 and development

By comparing the abundance of CD146 between embryonic tissues and mature tissues, it has been found that high levels of CD146 are expressed in epithelia of nervous systems [56], trachea [76], kidney [77,78] and oviduct [79] in embryonic tissues. After maturation, its protein levels decrease dramatically [80]. In addition, at the different stages of embryonic development, CD146 expression is variable. In early human embryos from 7 to 12 weeks of gestation, CD146 expression is higher compared with embryonic tissues after 16 weeks of gestation [1,3]. Among the investigations about CD146 participating in organogenesis, more attention is attracted in the importance of CD146 in development of nerves system, kidney [1,3,25,77], and retina [81].

8.1. CD146 with nerves system development

In chicken model system, it is clear CD146 is expressed during the developmental stage when neurons migrate or extend neurites to form a neural network through binding with NOF, an extracellular matrix glycoprotein of the laminin family [25,53,76,82], it is also found that CD146 participates in the development of the cerebellum [83], and peripheral nervous systems development [52,84]. CD146 promotes neurite extension and migration of embryonic neurons *in vitro* by its homophilic and heterophilic adhesion activities [80]. In mouse [56] and zebrafish model systems [85], CD146 is also identified to play the functional roles during nervous systems development as a neuron-specific gene. Thus, CD146 has been seen as a developmentally regulated CAM in neuroectodermal tissues [86]. Further accurate analysis of CD146 localization in central nervous system (CNS) reveals that CD146 is preferentially expressed on vasculature within the CNS but not on neurons and glial cells [87], suggesting that CD146 may promote nervous system development through facilitating adherence between neurons and glial cells with endothelial cells on vasculature.

8.2. CD146 with kidney development

CD146 is also involved in the formation of normal kidney by its homophilic and heterophilic adhesive activities. In the embryonic chicken, CD146 is considered to play a role in the normal development of kidney, because it is expressed abundantly in the embryonic organ and only slightly in the mature organ. After kidney development has been completed, CD146 expression is suppressed in most cell types in kidney [77]. Cell-aggregation assays further show that CD146 in primary culture cells from embryonic kidneys have strong aggregation activities than those cells from adult kidney. This is directly supported by the observation that CD146 from embryonic kidney but not from adult kidney binds to purified neurite outgrowth factor [78]. Contrast with this, increasing reports indicate that the close association of CD146 with kidney is required for function of normal kidney [38,88–90].

8.3. CD146 with retina development

During the retinal development of Japanese quail, CD146 is thought to be critical, because it was highly expressed in the devel-

opening retina but suppressed in the mature retina. When incubation with a CD146 antibody, this retina histogenesis was severely impaired [91]. CD146 is required for the retinal development is further supported by the study that an abnormal retina of mutant quail has no CD146 expression is found. Contrast with the mutant quail, CD146 protein was enriched in the normal retina of wild-type quail [81].

9. CD146 and immunology

Human CD146 is expressed by most elements of the microenvironment of normal human thymus, and is regarded as a pan-antigen with essential role for the maintenance of thymic architecture and function through mediating lymphocyte transmembrane migration and lymphocyte homing [92]. Human CD146 has been demonstrated to appear on a small subset of T [93] and B lymphocytes [94] in the peripheral blood of healthy individuals. By promoting the rolling on the inflammation marker VCAM-1 via microvilli induction and displaying adhesion receptor activity involving possible homophilic CD146–CD146 interactions, CD146 might be involved in the recruitment of activated T cells to inflammation sites [35]. Thus, CD146 may be involved in the extravasation and/or homing of activated T cells [93].

The concept that CD146 augments the tissue-infiltrative potential and inflammatory response in various inflammatory diseases has been supported by growing evidence. Increased levels of CD146 are positively correlated with active inflammatory reactions in idiopathic myopathy [95], chronically inflamed tissues [96], inflammatory skin disease [97], rheumatoid arthritis [98], inflammatory bowel disease [40,41], chronic obstructive pulmonary disease [99], and multiple sclerosis (MS) disease [61,100].

CD146 actively regulating inflammatory response is also evidenced from the investigation about avian and mouse CD146. Avian CD146 is also detected in lymphoid tissues such as the spleen and thymus [26]. In addition, it has been also identified as a marker of T lymphocyte progenitors in the bone marrow [26,101–103]. The CD146⁺ T cells display an immunophenotype consistent with effector memory cells and have a distinct gene profile from the CD146⁻ T cells [104,105]. Mouse CD146 has also been seen as a marker of mouse NK (natural killer) cell maturation to define final stages of NK cell maturation [106]. CD146⁺ NK cells are less cytotoxic and produce less IFN-gamma than CD146⁻ NK cells upon stimulation. In addition, over-expression of CD146 in NK cells decreased rolling velocity and increased cell adhesion to an endothelial cell monolayer and increased microvilli formation [107].

10. Signaling transduction by CD146

In addition to its role in cell–cell adhesion, CD146 participates in outside-in signaling in endothelial cells and is involved in the dynamics of actin cytoskeleton rearrangement. As shown in Fig. 3A, CD146 engagement initiates protein kinase phosphorylation cascade through association with Fyn, a Src family kinase. Phosphorylated Fyn in turn transfers phosphate to the downstream kinase of PKC- γ , which triggers Ca²⁺ burst within cells. Consequently, the induced association among proteins of P130, Pyk2, and paxillin, as well as the activated p125 (FAK) promotes polarization actions of actins. Thus, this CD146-mediated signaling pathway deciphers the mechanism that CD146 promotes normal cell motility and increases tumor cell invasiveness through transmitting the outside signals to downstream-signaling components for cytoskeleton remodeling [108,109].

CD146 transduction of proliferation signal through PI3K/AKT pathway provides rationale for tumor proliferation and survival (Fig. 3B). In melanoma, the expression level of CD146 is

reciprocally regulated by PI3K/AKT. Up-regulated CD146 activates endogenous PI3K/AKT, whose phosphorylation promotes CD146 expression in a positive feedback way. Although the exact mechanism underlying the reciprocal up-regulation between CD146 and PI3K/AKT remains elusive, the signaling axis of CD146/PI3K/AKT may manifest how CD146 inhibits apoptosis and increases survival ability of tumors. Whether or not a similar mechanism is also employed in normal cells, or in other tumor types remains unclear [110].

CD146 in cell signaling for up-regulating the expression of Id-1 depicts a possible mechanism by which CD146 contributes to melanoma metastasis (Fig. 3C). Id-1 is an oncogene in several malignancies, including melanoma. CD146 overexpression up-regulates Id-1 through down-regulation of ATF-3, a transcriptional inhibitor of Id-1 [111]. However, it is not clear whether CD146 up-regulating the expression of Id-1 is a universal phenomenon in all of malignant tumors or is just restricted to melanoma.

We have reported that CD146 is a novel target for tumor angiogenesis [112]. This exciting discovery arouses our great interest in the mechanism underlying CD146-induced angiogenesis. After systematic investigation, CD146-mediated signaling pathway came to prominence via CD146–CD146 dimerization on the cell surface. Over-expressed CD146 enhances an EMT process through up-regulation of transcriptional factor Slug, who controls the transcription of various EMT-related elements, such as MMP-9 [113,114]. More importantly, CD146 augments VEGFR/NF- κ B signaling with VEGFR-2 together as a co-receptor for VEGF ligand [115], provides further explicit evidence for the key role of CD146 on cancer metastasis through CD146/NF- κ B [116,117] as shown in Fig. 3D. However, better understanding its function in signaling transduction requires further study on its crosstalk with members of various signaling pathways.

11. CD146 and angiogenesis

Angiogenesis is the physiological process relating the growth of new blood vessels from pre-existing vessels. Angiogenesis is a normal and fundamental process in growth and development, as well as in wound healing and in granulation tissue. However, it is also an essential step in the transition of tumors from a dormant state to a malignant one, leading to the use of angiogenesis inhibitors for cancer treatment. Although modern terms of angiogenesis differentiate into vasculogenesis, angiogenesis, and arteriogenesis, the nature of angiogenesis is the formation of new blood vessels from endothelial cells present in pre-existing blood vessels.

Using zebrafish as a developmental model system, CD146 has been defined as a marker of vascular endothelial cells with high expression levels on the whole vascular tree during embryonic developmental stage, and plays crucial role for vascular development [108,118]. On the one hand, knockdown of CD146 protein expression severely hinders vascular development, leads to poorly developed intersomitic vessels, and lacks of blood flow through the intersomitic vessel region [34]; on the other hand, the gain-of-function analysis of CD146 in zebrafish, in which enforcing expression of CD146 constructs, induces sprouting angiogenesis [118].

Angiogenesis is also required for the spread of a tumor, or metastasis. Tumors induce angiogenesis through secreting various growth factors (e.g. VEGF, vascular endothelial growth factor) [119]. Already in 1994, Johnson and colleagues reported that CD146 was overly expressed in tumor blood vessels, and CD146 up-regulation was closely associated with tumor angiogenesis. They used monoclonal antibodies against three different epitopes of CD146 to determine the expression pattern of MUC18 in human tissues. This analysis showed that expression of CD146 is not only

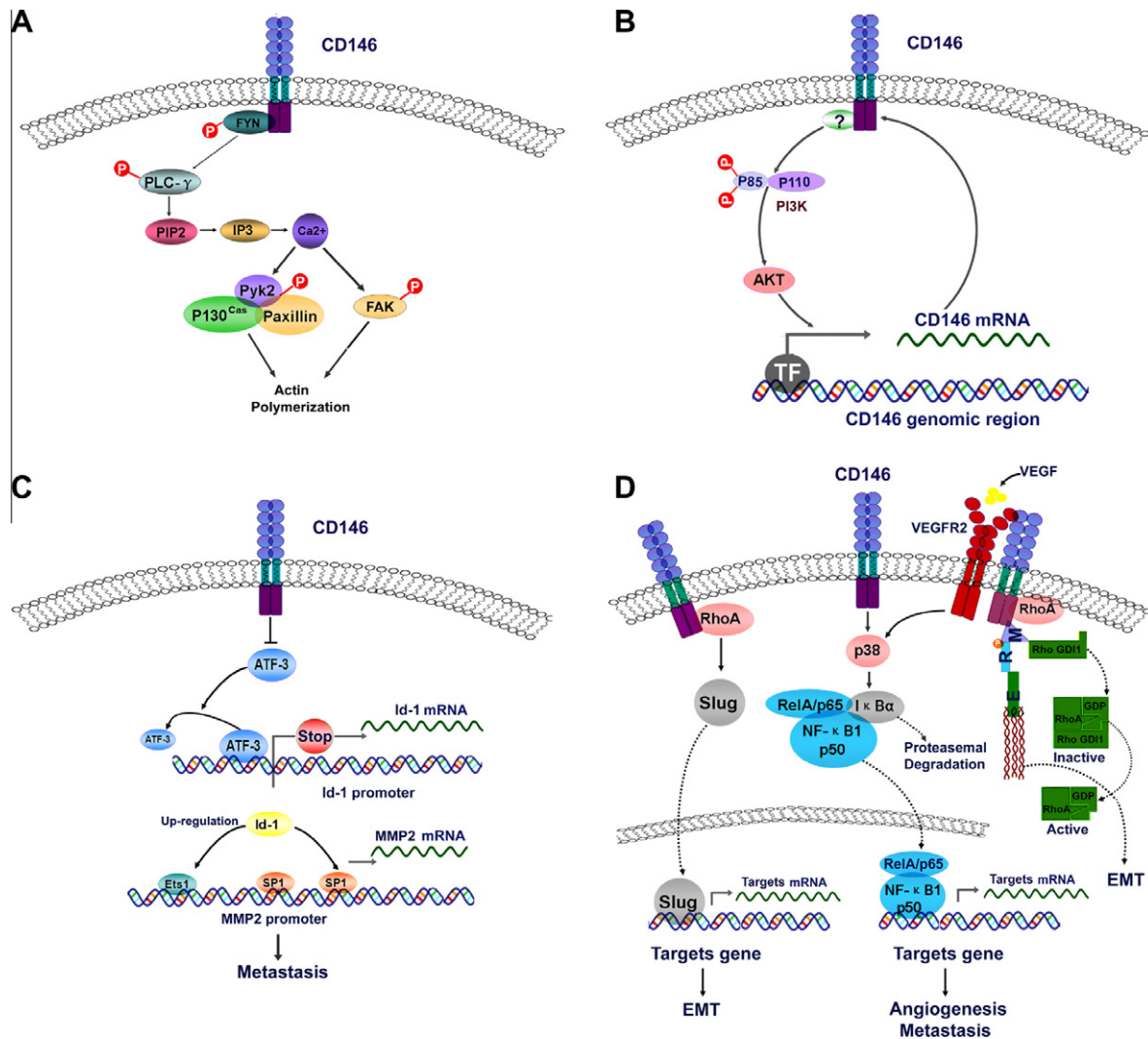

Fig. 3. CD146 mediated signaling pathways. (A) CD146 stimulates the tyrosine phosphorylation of focal adhesion kinase p125 (FAK) in human endothelial cells. (B) Reciprocal regulation of CD146 and AKT in human melanoma. (C) Expression of Id-1 is regulated by CD146. (D) CD146 activates NF-κB transcriptional factor through activating of P38 kinase.

present on melanoma cells but also on the endothelia of blood vessels penetrating primary and metastatic melanomas, suggesting a complex involvement of CD146 in tumor angiogenesis and metastasis [6]. However, whether CD146 is also involved in other types of tumors remains unknown.

During the pursuit of monoclonal antibodies (mAbs) against endothelial cell-surface proteins specific for tumor vasculature, we observed that anti-CD146 mAb AA98 showed remarkably restricted immunoreactivity against intratumoral neovasculature comparing with blood vessels of normal tissues. Angiogenesis was inhibited by mAb AA98 in chicken chorioallantoic membrane (CAM) assays and in three xenografted human tumor models in mice. Thus, in 2003, we proposed that CD146 may exert a pivotal role in angiogenesis of many types of tumors, providing the unambiguous evidence that CD146 is a certain target for tumor angiogenesis [112]. CD146 promoting tumor angiogenesis has been also observed in our subsequent systematic studies through tube-formation and wound healing assay [113]. The direct evidence of CD146 in tumor angiogenesis is that we find CD146 is a component of VEGF signalsome as a co-receptor with VEGFR-2 (vascular endothelial growth factor receptor-2) in tumor angiogenesis [115,117]. Therefore, through our long-term investigation of

CD146, we provide explicit evidence that CD146 is a promising target for combating abnormal vasculature in tumors.

12. CD146 and cancer

Sers et al. found that CD146 was highly expressed on advanced primary and metastatic melanomas but not on normal melanocyte, and that CD146 was associated with tumor progression and the development of metastasis in human malignant melanoma [5]. Subsequent investigations reveal that this protein was overly expressed in malignant and metastatic lesions [16,120] in most of cancer types for promotion of tumor progression and metastasis as summarized in Tables 1 and 2. Contrary to this, scarce observations report that CD146 is down-regulated or absent in some of cancers or cancer cell lines with tumor suppression functions [11].

The mechanism underlying the potential of CD146 in promoting tumor progression and metastasis has been attracting a plethora of attention. Through modulating its expression, over-expression of CD146 has been found to increase the motility and invasiveness of many tumor cells *in vitro* and metastasis *in vivo* by altering the expression of various elements in apoptosis, survival, prolifer-

Table 1
The consequence of elevated CD146 on cancer.

Cancer types	Consequences	Refs.
Melanoma	Increased metastasis and angiogenesis	[6,8,9,22,42,131–134]
Renal cell carcinoma	Increased recurrence rate	[135]
Gastric cancer	Increased EMT and poor prognosis	[136]
Lung adenocarcinoma	Poor overall survival rate	[137]
Gallbladder adenocarcinoma	Increased progression, invasion, and metastasis,	[138]
Malignant pleural mesothelioma	Poor prognosis	[139]
Adenoid cystic carcinoma	Increased progression	[140]
Breast tumors	Increased migration, aggressiveness, and EMT	[141–143]
Infantile haemangioma	Increased progression	[144]
Non-small cell lung cancer	Poor overall survival rate	[145]
Parotid carcinoma	Increased progression and invasion,	[146]
Prostate cancer	Increased metastasis	[147–149]
Peripheral nerve tumors	Increased malignant transformation	[150]
Hematological malignancies	Increased tumorigenesis	[151]
Chicken oviductal adenocarcinomas	Increased metastasis	[79]

Table 2
The consequence of elevated CD146 on cancer cell lines.

Cancer cell lines	Consequences	Refs.
Melanoma	Increased migration and metastasis	[114,152]
Breast cancer	Increased EMT	[113,122,153]
Osteosarcoma	Increased progression	[154]
Hepatocarcinoma	Increased angiogenesis	[128]
Prostate cancer	Increases tumorigenesis and metastasis	[23,155]
Ovarian cancer	Invasion and metastasis	[156]
Mouse prostate adenocarcinoma	Increased metastasis	[157]
Mouse melanoma	Increased tumorigenicity, motility, and metastasis	[31,158]
Rat colorectal adenocarcinoma	Increased metastasis	[159]
Mouse mammary carcinoma	Increased metastasis	[160]
Chicken lymphoma	Increased metastasis	[161]

ation, and angiogenesis. Recently, CD146 mediating hematogenous or lymphatic spreading of cancer cells indicates the possible route of CD146-resulted tumor metastasis [60,112,121]. CD146 overexpression increases angiogenesis ability by elevating levels of VEGF, VEGFR2, and CD31 points to another alternative way that CD146 affects tumor metastasis [23].

CD146 is highly expressed on the whole vascular tree during embryonic developmental stage in zebrafish [108]. Our laboratory finds that CD146 is overly expressed on tumor vessel compared with normal blood vessels [112] and enhances tumor angiogenesis through crosstalk with VEGFR2, which interact with VEGF that may be released from circulation [115]. Another role of CD146 in metastasis has been found that CD146 promotes an EMT (epithelial-mesenchymal transition), a critical step for tumor metastasis through modulating the remodeling of cytoskeleton [114,122]. Thus, defining its functional domains, its cognate ligand (s), and cofactor regulators may be crucial for untwisting the crucial step of CD146-mediated tumor metastasis.

13. CD146 as a target for cancer therapy

Over the past decades, “CD146 is an attractive target for cancer therapy” has been validated and documented by more than 50 investigations as summarized in Tables 1 and 2, and further summarized in many reviews [4,7,10–14]. Better understanding tumor growth and metastasis should obtain more insight on stromal microenvironment, such as the angiogenesis. Much research has been devoted to evaluating the reciprocal influences of angiogenesis with tumor development and progression. A more deeply exploring the complex parameters of tumor angiogenesis that impact the tumor progressions will help to improve anti-angiogenic

strategies, benefiting not only for cancer treatment, but also for preventing recurrence. CD146 has long been regarded as a biomarker of malignant metastasis or tumor angiogenesis [7]. Immunotherapy strategy targeting CD146 has been endeavored for tumor control and treatment [17,112].

Bar-Eli’s laboratory has successfully developed a fully humanized anti-CD146 antibody (ABX-MA1) [15,17,123]. Their preclinical studies clearly indicate that ABX-MA1 possesses strong effect on tumor growth, angiogenesis and metastasis of human melanoma. A375SM and WM2664 cells, two melanoma cell lines, with high expression levels of CD146 were used in the studies of xenografted human tumor models in mice. Mice treated with a once weekly injection of ABXMA1 developed smaller tumors at the injection site (after subcutaneous injection) and fewer lung metastases (after intravenous injection) compared with control IgG-treated mice. *In vitro* study shows that ABX-MA1 disrupts spheroid formation by melanoma cells with exogenously expressing CD146, impairs those cells to attach to human HUVEC cells, and significantly inhibits invasion activity of those cells through Matrigel-coated filters. ABX-MA1 may target both of the tumor and neo-vascular endothelial cells to inhibit tumor growth and metastasis of melanoma [15,17,123].

Our laboratory raised an array of mAbs against CD146, among which only AA98 binds with a conformational epitope (Fig. 4A), although AA1, AA2, and AA98 can bind to CD146 on living cells (Fig. 4B). The binding of AA98 with CD146 significantly impairs the dimmer formation of CD146, and thus blocking the signaling pathways mediated by CD146 (Fig. 4C) [112,124,125]. The powerful inhibitory effect of anti-CD146 mAb AA98 on tumor growth and on tumor angiogenesis has exhibited in several *in vivo* xenografted cancers, including melanoma, pancreatic and breast cancer [126–128]. At present, the mAb AA98 has been successfully developed

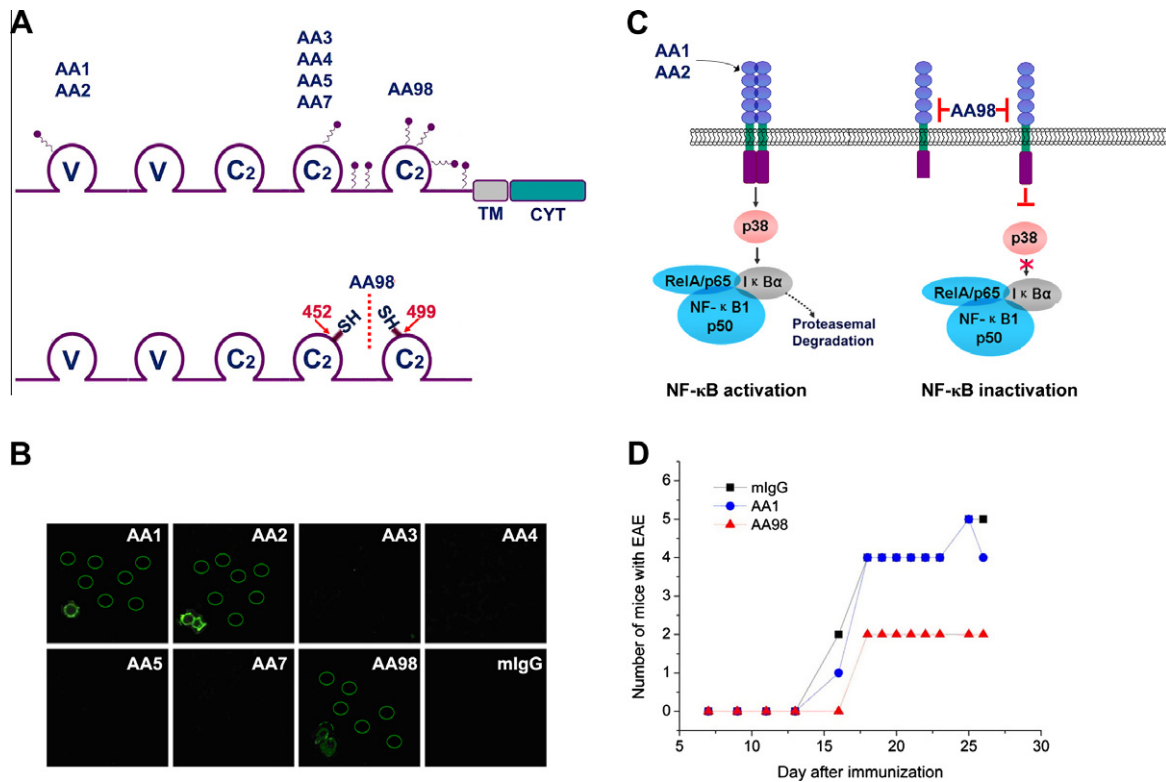

Fig. 4. Anti-CD146 antibody AA98 inhibits tumor growth and metastasis. (A) An array of mouse anti-CD146 antibodies was raised in Yan's laboratory. The epitope of AA 98 mAb is located within the conformational site, which is critical for dimer formation of CD146. (B) Antibodies of AA1, AA2, and AA98 recognize CD146 on living cell surface. (C) The AA 98 mAb, but not other mAbs, has blocking effect on CD146-mediated signaling pathway of NF- κ B activation. (D) AA 98 has powerful activity in inhibiting infiltration of T lymphocytes into CNS resulting in reduced EAE (experimental autoimmune encephalomyelitis) severity in mice.

as a novel tumor-targeting carrier and cancer therapeutics for preclinical trial. We propose that bioimmunotherapy against CD146 possesses promising therapeutic value toward tumor treatment (Fig. 4D). This notion is supported by investigations from other laboratories, which were tested in melanoma [129], in osteosarcoma [15], and in mesothelioma [130], respectively.

Altogether, these studies of anti-CD146 antibody imply that combined treatment strategy of anti-CD146 immunotherapy with other chemotherapeutic or anti-angiogenesis drugs may be a promising anti-cancer modality.

14. Concluding remarks

Increasing evidence demonstrates that CD146 is a multi-functional molecule implicated in a variety of biological and pathological processes. As a CAM, CD146 functions as a molecular mediator to facilitate inter-cellular interactions of homotypic or heterotypic cells, or to intervene in interactions of cell-to-extracellular matrix for responding to physiological signal. As a marker of endothelial cells in developmental vascular system and in tumor blood vessels, CD146 acts as a key player to be involved in neovascularization for angiogenesis. As a functional marker of mesenchymal stem cells (MSCs), CD146 behaves like a fate decision maker of MSCs to determine the tri-potency for their differentiation. Importantly, CD146 is implicated in the inflammatory response for promoting NK (natural killer) cells maturation and T cell homing to thymus. More importantly, as a marker of melanoma progression and metastasis, CD146 has been proved to be implicated in progression and metastasis in various malignant cancer types. In most clinical cases, its over expression contributes to virtually every phase of cancer progression, including tumor vascular angiogenesis, invasiveness, and

metastasis, and its expression levels are positively correlated with increased recurrence rate, poor prognosis, and poor survival rate.

Modern research has clearly portrayed CD146 as a receptor involved in transmitting 'outside-in' signaling implicated in the dynamic rearrangement of cytoskeleton. Regarding its signal transduction function, identifying its cognate ligand is an urgent need. There are three forms of CD146 found in divergent species, three isoforms of avian CD146 have been demonstrated to be generated from mRNA selective splicing; the origin of mouse CD146 two isoforms (CD146-l and CD146-s) are also from two splicing transcripts. Two isoforms of human CD146 were reported, but the human sCD146 has been believed to be produced from shedding of the CD146-l. Therefore, these controversies about the variety and the origination of CD146 isoforms should be resolved in the future. Soluble CD146 may play a role in regulation of thymus homing, inhibiting progenitor/endothelial cell adhesion by competitive binding to its ligands on the plasma membrane.

Better understanding the function of CD146 will not only benefit for investigation of CD146-related physiological processes, but also for CD146-associated pathological progressions, such as cancerous progression. It is crucial to define CD146 functional domains through analysis of its crystal structure, which will be useful for designing drugs against CD146, such as small molecule peptide. Because it is well established that chronic inflammation accounts for about 25% of all cancer cases worldwide, clarification of CD146-mediated immune response during cancer progression should be an interesting area about how CD146 influences the aberrant immune response in cancers. Combining CD146-targeted bioimmunotherapy with classical chemotherapy and radiotherapy is a promising strategy because manifold dose regimens of the antibodies could be applied to the patients without risk of escalating an immune reaction. We have successfully developed fully humanized antibody to block CD146 for suppressing its metastasis.

sis-promotion effects. The preclinical trial of using humanized CD146 antibody has been used to treat cancer patients. Initiating Phase I to Phase III clinical trial with humanized CD146 antibody in patients with a variety of cancers is under our serious consideration.

Acknowledgements

We would like to thank our esteemed colleagues for carefully reading this manuscript and contributing to the progress of this work with their evaluation and insight. This work was partially sponsored by the National Natural Science Foundation China Grant 81272409, National Natural Science Foundation China Key Grant 91029732, and by Chinese State Key Programs for Basic Research (973) 2009CB521704.

References

- [1] J.M. Lehmann, B. Holzmann, E.W. Breitbart, P. Schmiegelow, G. Riethmuller, J.P. Johnson, Discrimination between benign and malignant cells of melanocytic lineage by two novel antigens, a glycoprotein with a molecular weight of 113,000 and a protein with a molecular weight of 76,000, *Cancer Res.* 47 (1987) 841–845.
- [2] M. Trzpis, P.M. McLaughlin, L.M. de Leij, M.C. Harmsen, Epithelial cell adhesion molecule: more than a carcinoma marker and adhesion molecule, *Am. J. Pathol.* 171 (2007) 386–395.
- [3] J.M. Lehmann, G. Riethmuller, J.P. Johnson, MUC18, a marker of tumor progression in human melanoma, shows sequence similarity to the neural cell adhesion molecules of the immunoglobulin superfamily, *Proc. Natl. Acad. Sci. USA* 86 (1989) 9891–9895.
- [4] J.P. Johnson, U. Rothbacher, C. Sers, The progression associated antigen MUC18: a unique member of the immunoglobulin supergene family, *Melanoma Res.* 3 (1993) 337–340.
- [5] C. Sers, K. Kirsch, U. Rothbacher, G. Riethmuller, J.P. Johnson, Genomic organization of the melanoma-associated glycoprotein MUC18: implications for the evolution of the immunoglobulin domains, *Proc. Natl. Acad. Sci. USA* (1993) 8514–8518.
- [6] C. Sers, G. Riethmuller, J.P. Johnson, MUC18, a melanoma-progression associated molecule, and its potential role in tumor vascularization and hematogenous spread, *Cancer Res.* 54 (1994) 5689–5694.
- [7] J.P. Johnson, M.M. Rummel, U. Rothbacher, C. Sers, MUC18: a cell adhesion molecule with a potential role in tumor growth and tumor cell dissemination, *Curr. Top. Microbiol. Immunol.* 213 (Pt 1) (1996) 95–105.
- [8] I.M. Shih, D.E. Elder, M.Y. Hsu, M. Herlyn, Regulation of Mel-CAM/MUC18 expression on melanocytes of different stages of tumor progression by normal keratinocytes, *Am. J. Pathol.* 145 (1994) 837–845.
- [9] I.M. Shih, D.E. Elder, D. Speicher, J.P. Johnson, M. Herlyn, Isolation and functional characterization of the A32 melanoma-associated antigen, *Cancer Res.* 54 (1994) 2514–2520.
- [10] I.M. Shih, The role of CD146 (Mel-CAM) in biology and pathology, *J. Pathol.* 189 (1999) 4–11.
- [11] G.J. Wu, Dual roles of METCAM in the progression of different cancers, *J. Oncol.* 2012 (2012) 853797.
- [12] J.P. Johnson, Cell adhesion molecules of the immunoglobulin supergene family and their role in malignant transformation and progression to metastatic disease, *Cancer Metastasis Rev.* 10 (1991) 11–22.
- [13] J.P. Johnson, Cell adhesion molecules in neoplastic disease, *Int. J. Clin. Lab. Res.* 22 (1992) 69–72.
- [14] J.P. Johnson, Cell adhesion molecules in the development and progression of malignant melanoma, *Cancer Metastasis Rev.* 18 (1999) 345–357.
- [15] E.C. McGary, A. Heimberger, L. Mills, K. Weber, G.W. Thomas, M. Shitvelband, D.C. Lev, M. Bar-Eli, A fully human antimelanoma cellular adhesion molecule/MUC18 antibody inhibits spontaneous pulmonary metastasis of osteosarcoma cells in vivo, *Clin. Cancer Res.* 9 (2003) 6560–6566.
- [16] V.O. Melnikova, M. Bar-Eli, Bioimmunotherapy for melanoma using fully human antibodies targeting MCAM/MUC18 and IL-8, *Pigment Cell Res.* 19 (2006) 395–405.
- [17] L. Mills, C. Tellez, S. Huang, C. Baker, M. McCarty, L. Green, J.M. Gudas, X. Feng, M. Bar-Eli, Fully human antibodies to MCAM/MUC18 inhibit tumor growth and metastasis of human melanoma, *Cancer Res.* 62 (2002) 5106–5114.
- [18] C. Hafner, U. Samwald, S. Wagner, F. Felici, E. Heere-Ress, E. Jensen-Jarolim, K. Wolff, O. Scheiner, H. Pehamberger, H. Breiteneder, Selection of mimotopes of the cell surface adhesion molecule Mel-CAM from a random pVIII-28aa phage peptide library, *J. Invest. Dermatol.* 119 (2002) 865–869.
- [19] C. Hafner, S. Wagner, J. Jasinska, D. Allwardt, O. Scheiner, K. Wolff, H. Pehamberger, U. Wiedermann, H. Breiteneder, Epitope-specific antibody response to Mel-CAM induced by mimotope immunization, *J. Invest. Dermatol.* 124 (2005) 125–131.
- [20] N. Bardin, V. Frances, G. Lesaulle, N. Horschowski, F. George, J. Sampol, Identification of the S-Endo 1 endothelial-associated antigen, *Biochem. Biophys. Res. Commun.* 218 (1996) 210–216.
- [21] M.M. Rummel, C. Sers, J.P. Johnson, Phorbol ester and cyclic AMP-mediated regulation of the melanoma-associated cell adhesion molecule MUC18/MCAM, *Cancer Res.* 56 (1996) 2218–2223.
- [22] S. Xie, M. Luca, S. Huang, M. Gutman, R. Reich, J.P. Johnson, M. Bar-Eli, Expression of MCAM/MUC18 by human melanoma cells leads to increased tumor growth and metastasis, *Cancer Res.* 57 (1997) 2295–2303.
- [23] G.J. Wu, M.W. Wu, C. Wang, Y. Liu, Enforced expression of METCAM/MUC18 increases tumorigenesis of human prostate cancer LNCaP cells in nude mice, *J. Urol.* 185 (2011) 1504–1512.
- [24] H. Taniura, C.H. Kuo, Y. Hayashi, N. Miki, Purification and characterization of an 82-kD membrane protein as a neurite outgrowth factor binding protein: possible involvement of NOF binding protein in axonal outgrowth in developing retina, *J. Cell Biol.* 112 (1991) 313–322.
- [25] E. Taira, N. Takaha, H. Taniura, C.H. Kim, N. Miki, Molecular cloning and functional expression of gicerin, a novel cell adhesion molecule that binds to neurite outgrowth factor, *Neuron* 12 (1994) 861–872.
- [26] O. Vainio, D. Dunon, F. Aissi, J.P. Dangy, K.M. McNagny, B.A. Imhof, HEMCAM, an adhesion molecule expressed by c-kit⁺ hemopoietic progenitors, *J. Cell Biol.* 135 (1996) 1655–1668.
- [27] K. Kohama, Y. Tsukamoto, M. Furuya, K. Okamura, H. Tanaka, N. Miki, E. Taira, Molecular cloning and analysis of the mouse gicerin gene, *Neurochem. Int.* 46 (2005) 465–470.
- [28] D. Jean, J.E. Gershenwald, S. Huang, M. Luca, M.J. Hudson, M.A. Tainsky, M. Bar-Eli, Loss of AP-2 results in up-regulation of MCAM/MUC18 and an increase in tumor growth and metastasis of human melanoma cells, *J. Biol. Chem.* 273 (1998) 16501–16508.
- [29] C.S. Mintz-Weber, J.P. Johnson, Identification of the elements regulating the expression of the cell adhesion molecule MCAM/MUC18. Loss of AP-2 is not required for MCAM expression in melanoma cell lines, *J. Biol. Chem.* 275 (2000) 34672–34680.
- [30] S. Alais, N. Allili, C. Pujades, J.L. Duband, O. Vainio, B.A. Imhof, D. Dunon, HEMCAM/CD146 downregulates cell surface expression of beta1 integrins, *J. Cell Sci.* 114 (2001) 1847–1859.
- [31] H. Yang, S. Wang, Z. Liu, M.H. Wu, B. McAlpine, J. Ansel, C. Armstrong, G. Wu, Isolation and characterization of mouse MUC18 cDNA gene, and correlation of MUC18 expression in mouse melanoma cell lines with metastatic ability, *Gene* 265 (2001) 133–145.
- [32] S. Okumura, O. Muraoka, Y. Tsukamoto, H. Tanaka, K. Kohama, N. Miki, E. Taira, Involvement of gicerin in the extension of microvilli, *Exp. Cell Res.* 271 (2001) 269–276.
- [33] S. Okumura, K. Kohama, S. Kim, H. Iwao, N. Miki, E. Taira, Induction of gicerin/CD146 in the rat carotid artery after balloon injury, *Biochem. Biophys. Res. Commun.* 313 (2004) 902–906.
- [34] B. Chan, S. Sinha, D. Cho, R. Ramchandran, V.P. Sukhatme, Critical roles of CD146 in zebrafish vascular development, *Dev. Dyn.* 232 (2005) 232–244.
- [35] B. Guezguez, P. Vigneron, N. Lamerant, C. Kieda, T. Jaffredo, D. Dunon, Dual role of melanoma cell adhesion molecule (MCAM)/CD146 in lymphocyte endothelium interaction: MCAM/CD146 promotes rolling via microvilli induction in lymphocyte and is an endothelial adhesion receptor, *J. Immunol.* 179 (2007) 6673–6685.
- [36] E. Taira, T. Nagino, Y. Tsukamoto, S. Okumura, O. Muraoka, F. Sakuma, N. Miki, H. Higuchi, N. Miki, Expression and functional analysis of a novel isoform of gicerin, an immunoglobulin superfamily cell adhesion molecule, *J. Biol. Chem.* 270 (1995) 28681–28687.
- [37] N. Bardin, V. Frances, V. Combes, J. Sampol, F. Dignat-George, CD146: biosynthesis and production of a soluble form in human cultured endothelial cells, *FEBS Lett.* 421 (1998) 12–14.
- [38] N. Bardin, V. Moal, F. Anfosso, L. Daniel, P. Brunet, J. Sampol, F. Dignat George, Soluble CD146, a novel endothelial marker, is increased in physiopathological settings linked to endothelial junctional alteration, *Thromb. Haemost.* 90 (2003) 915–920.
- [39] E. Taira, T. Nagino, Y. Tsukamoto, S. Okumura, O. Muraoka, F. Sakuma, N. Miki, Cytoplasmic domain is not essential for the cell adhesion activities of gicerin, an Ig-superfamily molecule, *Exp. Cell Res.* 253 (1999) 697–703.
- [40] N. Bardin, D. Reumaux, K. Geboes, J.F. Colombel, M. Blot-Chabaud, J. Sampol, P. Duthilleul, F. Dignat-George, Increased expression of CD146, a new marker of the endothelial junction in active inflammatory bowel disease, *Inflamm. Bowel Dis.* 12 (2006) 16–21.
- [41] N. Bardin, M. Blot-Chabaud, N. Despoix, A. Kebir, K. Harhour, J.P. Arsanto, L. Espinosa, P. Perrin, S. Robert, F. Vely, F. Sabatier, A. Le Bivic, G. Kaplanski, J. Sampol, F. Dignat-George, CD146 and its soluble form regulate monocyte transendothelial migration, *Arterioscler. Thromb. Vasc. Biol.* 29 (2009) 746–753.
- [42] M. Luca, B. Hunt, C.D. Bucana, J.P. Johnson, I.J. Fidler, M. Bar-Eli, Direct correlation between MUC18 expression and metastatic potential of human melanoma cells, *Melanoma Res.* 3 (1993) 35–41.
- [43] C. Corbel, F. Cormier, O. Pourquie, H.G. Bluestein, BEN, a novel surface molecule of the immunoglobulin superfamily on avian hemopoietic progenitor cells shared with neural cells, *Exp. Cell Res.* 203 (1992) 91–99.
- [44] J.W. Liu, J.K. Nagpal, C. Jeronimo, J.E. Lee, R. Henrique, M.S. Kim, K.L. Ostrow, K. Yamashita, V. van Criekinge, G. Wu, C.S. Moon, B. Trink, D. Sidransky, Hypermethylation of MCAM gene is associated with advanced tumor stage in prostate cancer, *Prostate* 68 (2008) 418–426.
- [45] S. Yoshioka, H. Fujiwara, T. Higuchi, S. Yamada, M. Maeda, S. Fujii, Melanoma cell adhesion molecule (MCAM/CD146) is expressed on human luteinizing

- granulosa cells: enhancement of its expression by HCG, interleukin-1 and tumour necrosis factor- α , *Mol. Hum. Reprod.* 9 (2003) 311–319.
- [46] T. Higuchi, H. Fujiwara, H. Egawa, Y. Sato, S. Yoshioka, K. Tatsumi, K. Itoh, M. Maeda, J. Fujita, S. Fujii, Cyclic AMP enhances the expression of an extravillous trophoblast marker, melanoma cell adhesion molecule, in choriocarcinoma cell JEG3 and human chorionic villous explant cultures, *Mol. Hum. Reprod.* 9 (2003) 359–366.
- [47] G.C. Simon, R.J. Martin, S. Smith, J. Thaikootathil, R.P. Bowler, S.J. Barenkamp, H.W. Chu, Up-regulation of MUC18 in airway epithelial cells by IL-13: implications in bacterial adherence, *Am. J. Respir. Cell Mol. Biol.* 44 (2011) 606–613.
- [48] N. Wang, Y. Fan, P. Ni, F. Wang, X. Gao, Q. Xue, L. Tang, High glucose effect on the role of CD146 in human proximal tubular epithelial cells in vitro, *J. Nephrol.* 21 (2008) 931–940.
- [49] M. Schon, T. Kahne, H. Gollnick, M.P. Schon, Expression of gp130 in tumors and inflammatory disorders of the skin: formal proof of its identity as CD146 (MUC18, Mel-CAM), *J. Invest. Dermatol.* 125 (2005) 353–363.
- [50] C.R. Mangahas, G.V. dela Cruz, R.J. Schneider, S. Jamal, Endothelin-1 upregulates MCAM in melanocytes, *J. Invest. Dermatol.* 123 (2004) 1135–1139.
- [51] S. Tsuchiya, Y. Tsukamoto, E. Taira, J. LaMarre, Involvement of transforming growth factor- β in the expression of gicerin, a cell adhesion molecule, in the regeneration of hepatocytes, *Int. J. Mol. Med.* 19 (2007) 381–386.
- [52] S. Hiroi, E. Taira, K. Ogawa, Y. Tsukamoto, Neurite extension of DRG neurons by gicerin expression is enhanced by nerve growth factor, *Int. J. Mol. Med.* 16 (2005) 1009–1014.
- [53] E. Taira, K. Kohama, Y. Tsukamoto, S. Okumura, N. Miki, Gicerin/CD146 is involved in neurite extension of NGF-treated PC12 cells, *J. Cell. Physiol.* 204 (2005) 632–637.
- [54] V.O. Melnikova, K. Balasubramanian, G.J. Villares, A.S. Dobroff, M. Zigler, H. Wang, F. Petersson, J.E. Price, A. Schroit, V.G. Prieto, M.C. Hung, M. Bar-Eli, Crosstalk between protease-activated receptor 1 and platelet-activating factor receptor regulates melanoma cell adhesion molecule (MCAM/MUC18) expression and melanoma metastasis, *J. Biol. Chem.* 284 (2009) 28845–28855.
- [55] E. Taira, Functional analysis of a novel cell adhesion molecule, gicerin, *Nihon Yakurigaku Zasshi* 113 (1999) 133–143.
- [56] E. Taira, K. Kohama, Y. Tsukamoto, S. Okumura, N. Miki, Characterization of Gicerin/MUC18/CD146 in the rat nervous system, *J. Cell. Physiol.* 198 (2004) 377–387.
- [57] E. Taira, N. Miki, Gicerin, *Tanpakushitsu Kakusan Koso* 42 (1997) 561–566.
- [58] E. Taira, T. Nagino, Y. Tsukamoto, Y. Ding, S. Sakuma, N. Miki, Neurite promotion from ciliary ganglion neurons by gicerin, *Neurochem. Int.* 32 (1998) 23–29.
- [59] J.P. Johnson, M. Bar-Eli, B. Jansen, E. Markhof, Melanoma progression-associated glycoprotein MUC18/MCAM mediates homotypic cell adhesion through interaction with a heterophilic ligand, *Int. J. Cancer* 73 (1997) 769–774.
- [60] N. Bardin, F. Anfoso, J.M. Masse, E. Cramer, F. Sabatier, A. Le Bivic, J. Sampol, F. Dignat-George, Identification of CD146 as a component of the endothelial junction involved in the control of cell-cell cohesion, *Blood* 98 (2001) 3677–3684.
- [61] K. Flanagan, K. Fitzgerald, J. Baker, K. Regnstrom, S. Gardai, F. Bard, S. Mocchi, P. Seto, M. You, C. Larochele, A. Prat, S. Chow, L. Li, C. Vandevent, W. Zago, C. Lorenzana, C. Nishioka, J. Hoffman, R. Botelho, C. Willits, K. Tanaka, J. Johnston, T. Yednock, Laminin-411 Is a Vascular Ligand for MCAM and Facilitates TH17 Cell Entry into the CNS, *PLoS ONE* 7 (2012) e40443.
- [62] I.M. Shih, D. Speicher, M.Y. Hsu, E. Levine, M. Herlyn, Melanoma cell-cell interactions are mediated through heterophilic Mel-CAM/ligand adhesion, *Cancer Res.* 57 (1997) 3835–3840.
- [63] I. Shih, T. Wang, T. Wu, R.J. Kurman, J.D. Gearhart, Expression of Mel-CAM in implantation site intermediate trophoblastic cell line, IST-1, limits its migration on uterine smooth muscle cells, *J. Cell Sci.* 111 (Pt 17) (1998) 2655–2664.
- [64] I.M. Shih, R.J. Kurman, Expression of melanoma cell adhesion molecule in intermediate trophoblast, *Lab. Invest.* 75 (1996) 377–388.
- [65] E. Pasquier, N. Bardin, L. De Saint Martin, M.T. Le Martelot, C. Bohec, S. Roche, D. Mottier, F. Dignat-George, The first assessment of soluble CD146 in women with unexplained pregnancy loss. A new insight?, *Thromb Haemost.* 94 (2005) 1280–1284.
- [66] Q. Liu, X. Yan, Y. Li, Y. Zhang, X. Zhao, Y. Shen, Pre-eclampsia is associated with the failure of melanoma cell adhesion molecule (MCAM/CD146) expression by intermediate trophoblast, *Lab. Invest.* 84 (2004) 221–228.
- [67] Q. Liu, B. Zhang, X. Zhao, Y. Zhang, Y. Liu, X. Yan, Blockade of adhesion molecule CD146 causes pregnancy failure in mice, *J. Cell. Physiol.* 215 (2008) 621–626.
- [68] S. Shi, S. Gronthos, Perivascular niche of postnatal mesenchymal stem cells in human bone marrow and dental pulp, *J. Bone Miner. Res.* 18 (2003) 696–704.
- [69] S.C. Chen, V. Marino, S. Gronthos, P.M. Bartold, Location of putative stem cells in human periodontal ligament, *J. Periodontol. Res.* 41 (2006) 547–553.
- [70] D. Baksh, R. Yao, R.S. Tuan, Comparison of proliferative and multilineage differentiation potential of human mesenchymal stem cells derived from umbilical cord and bone marrow, *Stem cells* 25 (2007) 1384–1392.
- [71] D.T. Covas, R.A. Panepucci, A.M. Fontes, W.A. Silva Jr., M.D. Orellana, M.C. Freitas, L. Neder, A.R. Santos, L.C. Peres, M.C. Jamur, M.A. Zago, Multipotent mesenchymal stromal cells obtained from diverse human tissues share functional properties and gene-expression profile with CD146+ perivascular cells and fibroblasts, *Exp. Hematol.* 36 (2008) 642–654.
- [72] A. Sorrentino, M. Ferracin, G. Castellani, M. Biffoni, G. Tomaselli, M. Baiocchi, A. Fatica, M. Negri, C. Peschle, M. Valtieri, Isolation and characterization of CD146+ multipotent mesenchymal stromal cells, *Exp. Hematol.* 36 (2008) 1035–1046.
- [73] J. Xu, W. Wang, Y. Kapila, J. Lotz, S. Kapila, Multiple differentiation capacity of STRO-1+/CD146+ PDL mesenchymal progenitor cells, *Stem Cells Dev* 18 (2009) 487–496.
- [74] K.C. Russell, D.G. Phinney, M.R. Lacey, B.L. Barrilleaux, K.E. Meyertholen, K.C. O'Connor, In vitro high-capacity assay to quantify the clonal heterogeneity in trilineage potential of mesenchymal stem cells reveals a complex hierarchy of lineage commitment, *Stem cells* 28 (2010) 788–798.
- [75] A. Torrin, O. Li, J.C. Brune, S. Walsh, B. Schutz, M. Ehinger, N. Ditzel, M. Kassem, S. Scheding, CD146 expression on primary nonhematopoietic bone marrow stem cells is correlated with in situ localization, *Blood* 117 (2011) 5067–5077.
- [76] Y. Tsukamoto, E. Taira, T. Kotani, J. Yamate, S. Wada, N. Takaha, N. Miki, S. Sakuma, Involvement of gicerin, a cell adhesion molecule, in tracheal development and regeneration, *Cell Growth Differ.* 7 (1996) 1761–1767.
- [77] N. Takaha, E. Taira, H. Taniura, T. Nagino, Y. Tsukamoto, T. Matsumoto, T. Kotani, S. Sakuma, N. Miki, Expression of gicerin in development, oncogenesis and regeneration of the chick kidney, *Differentiation* 58 (1995) 313–320.
- [78] Y. Tsukamoto, T. Matsumoto, E. Taira, T. Kotani, J. Yamate, N. Takaha, R. Tatesaki, T. Namikawa, N. Miki, S. Sakuma, Adhesive activity of gicerin, a cell-adhesion molecule, in kidneys and nephroblastomas of chickens, *Cell Tissue Res.* 292 (1998) 137–142.
- [79] Y. Tsukamoto, E. Taira, K. Kajimura, J. Yamate, T. Kotani, H. Amin, K. Kohama, S. Sakuma, N. Miki, F. Sasaki, Involvement of gicerin, a cell adhesion molecule, in development and regeneration of oviduct and metastasis of oviductal adenocarcinomas of the chicken, *Exp. Cell Res.* 247 (1999) 329–338.
- [80] Y. Tsukamoto, E. Taira, N. Miki, F. Sasaki, The role of gicerin, a novel cell adhesion molecule, in development, regeneration and neoplasia, *Histol. Histopathol.* 16 (2001) 563–571.
- [81] Y. Tsukamoto, E. Taira, Y. Nakane, M. Tsudzuki, K. Kohama, H. Amin, N. Miki, F. Sasaki, Expression of gicerin, a cell adhesion molecule, in the abnormal retina in silver plumage color mutation of Japanese quail (*Coturnix japonica*), *Neurosci. Lett.* 266 (1999) 53–56.
- [82] Y. Tsukamoto, E. Taira, J. Yamate, Y. Nakane, K. Kajimura, M. Tsudzuki, Y. Kiso, T. Kotani, N. Miki, S. Sakuma, Gicerin, a cell adhesion molecule, participates in the histogenesis of retina, *J. Neurobiol.* 33 (1997) 769–780.
- [83] S. Kato, H. Taniura, E. Taira, N. Miki, Involvement of a receptor for neurite outgrowth factor (NOFR) in cerebellar neurogenesis, *Neurosci. Lett.* 140 (1992) 78–80.
- [84] S. Hiroi, Y. Tsukamoto, F. Sasaki, N. Miki, E. Taira, Involvement of gicerin, a cell adhesion molecule, in development and regeneration of chick sciatic nerve, *FEBS Lett.* 554 (2003) 311–314.
- [85] C.H. Kim, E. Taira, C.H. Kuo, B.S. Li, H. Okamoto, K. Nakahira, K. Ikenaka, H. Higuchi, N. Miki, Neuron-specific expression of a chicken gicerin cDNA in transient transgenic zebrafish, *Neurochem. Res.* 21 (1996) 231–237.
- [86] H. Hampel, D.A. Korschenhausen, M.J. Schwarz, K.H. Frenzel, J.P. Johnson, R. Penning, M. Ackenheil, N. Muller, Detection of the novel cell adhesion molecule MUC18 in human brain tissue, *NeuroImmunoModulation* 4 (1997) 57–61.
- [87] M.J. Schwarz, N. Muller, D. Korschenhausen, K.H. Kirsch, R. Penning, M. Ackenheil, J.P. Johnson, H. Hampel, Melanoma-associated adhesion molecule MUC18/MCAM (CD146) and transcriptional regulator mader in normal human CNS, *NeuroImmunoModulation* 5 (1998) 270–276.
- [88] L. Daniel, N. Bardin, V. Moal, F. Dignat-George, Y. Berland, D. Figarella-Branger, Tubular CD146 expression in nephropathies is related to chronic renal failure, *Nephron Exp. Nephrol.* 99 (2005) e105–111.
- [89] J. Malyszko, J.S. Malyszko, S. Brzosko, S. Wolczynski, M. Mysliwiec, Markers of endothelial cell activation/injury: CD146 and thrombomodulin are related to adiponectin in kidney allograft recipients, *Am. J. Nephrol.* 25 (2005) 203–210.
- [90] J. Malyszko, J.S. Malyszko, S. Brzosko, S. Wolczynski, M. Mysliwiec, Adiponectin is related to CD146, a novel marker of endothelial cell activation/injury in chronic renal failure and peritoneally dialyzed patients, *J. Clin. Endocrinol. Metab.* 89 (2004) 4620–4627.
- [91] Y. Tsukamoto, T. Matsumoto, T. Kotani, E. Taira, N. Takaha, N. Miki, J. Yamate, S. Sakuma, The expression of gicerin, a cell adhesion molecule, in regenerating process of collecting ducts and ureters of the chicken kidney following infection with a nephrotropic strain of infectious bronchitis virus, *Avian Pathol.* 26 (1997) 245–255.
- [92] A. Seftalioglu, L. Karakoc, Expression of CD146 adhesion molecules (MUC18 or MCAM) in the thymic microenvironment, *Acta Histochem.* 102 (2000) 69–83.
- [93] W.F. Pickl, O. Majdic, G.F. Fischer, P. Petzelbauer, I. Fae, M. Waclavicek, J. Stockl, C. Scheinecker, T. Vidicki, H. Aschauer, J.P. Johnson, W. Knapp, MUC18/MCAM (CD146), an activation antigen of human T lymphocytes, *J. Immunol.* 158 (1997) 2107–2115.
- [94] F.I. Staquicini, A. Tandle, S.K. Libutti, J. Sun, M. Zigler, M. Bar-Eli, F. Aliperti, E.C. Perez, J.E. Gershenwald, M. Mariano, R. Pasqualini, W. Arap, J.D. Lopes, A subset of host B lymphocytes controls melanoma metastasis through a melanoma cell adhesion molecule/MUC18-dependent interaction: evidence from mice and humans, *Cancer Res.* 68 (2008) 8419–8428.

- [95] D. Figarella-Branger, N. Schleinitz, B. Boutiere-Albanese, L. Camoin, N. Bardin, S. Guis, J. Pouget, C. Cognet, J.F. Pellissier, F. Dignat-George, Platelet-endothelial cell adhesion molecule-1 and CD146: soluble levels and in situ expression of cellular adhesion molecules implicated in the cohesion of endothelial cells in idiopathic inflammatory myopathies, *J. Rheumatol.* 33 (2006) 1623–1630.
- [96] J. Middleton, L. Americh, R. Gayon, D. Julien, M. Mansat, P. Mansat, P. Anract, A. Cantagrel, P. Cattani, J.M. Reimund, L. Aguilar, F. Amalric, J.P. Girard, A comparative study of endothelial cell markers expressed in chronically inflamed human tissues: MECA-79, Duffy antigen receptor for chemokines, von Willebrand factor, CD31, CD34, CD105 and CD146, *J. Pathol.* 206 (2005) 260–268.
- [97] W. Weninger, M. Rendl, M. Mildner, C. Mayer, J. Ban, A. Gausau, G. Bayer, A. Tanew, O. Majdic, E. Tschachler, Keratinocytes express the CD146 (Muc18/S-endo) antigen in tissue culture and during inflammatory skin diseases, *J. Invest. Dermatol.* 115 (2000) 219–224.
- [98] M. Neidhart, R. Wehrli, P. Brühlmann, B.A. Michel, R.E. Gay, S. Gay, Synovial fluid CD146 (MUC18), a marker for synovial membrane angiogenesis in rheumatoid arthritis, *Arthritis Rheum.* 42 (1999) 622–630.
- [99] C. Schulz, V. Petrig, K. Wolf, K. Kratzel, M. Kohler, B. Becker, M. Pfeifer, Upregulation of MCAM in primary bronchial epithelial cells from patients with COPD, *Eur. Respir. J.* 22 (2003) 450–456.
- [100] P.K. Dagur, A. Biancotto, L. Wei, H.N. Sen, M. Yao, W. Strober, R.B. Nussenblatt, J. Philip McCoy Jr., MCAM-expressing CD4(+) T cells in peripheral blood secrete IL-17A and are significantly elevated in inflammatory autoimmune diseases, *J. Autoimmun.* 37 (2011) 319–327.
- [101] D. Dunon, N. Allioli, O. Vainio, C. Ody, B.A. Imhof, Renewal of thymocyte progenitors and emigration of thymocytes during avian development, *Dev. Comp. Immunol.* 22 (1998) 279–287.
- [102] D. Dunon, N. Allioli, O. Vainio, C. Ody, B.A. Imhof, Quantification of T-cell progenitors during ontogeny: thymus colonization depends on blood delivery of progenitors, *Blood* 93 (1999) 2234–2243.
- [103] C. Ody, S. Alais, C. Corbel, K.M. McNagny, T.F. Davison, O. Vainio, B.A. Imhof, D. Dunon, Surface molecules involved in avian T-cell progenitor migration and differentiation, *Dev. Immunol.* 7 (2000) 267–277.
- [104] M.F. Elshal, S.S. Khan, Y. Takahashi, M.A. Solomon, J.P. McCoy Jr., CD146 (Mel-CAM), an adhesion marker of endothelial cells, is a novel marker of lymphocyte subset activation in normal peripheral blood, *Blood* 106 (2005) 2923–2924.
- [105] M.F. Elshal, S.S. Khan, N. Raghavachari, Y. Takahashi, J. Barb, J.J. Bailey, P.J. Munson, M.A. Solomon, R.L. Danner, J.P. McCoy Jr., A unique population of effector memory lymphocytes identified by CD146 having a distinct immunophenotypic and genomic profile, *BMC Immunol.* 8 (2007) 29.
- [106] N. Despoix, T. Walzer, N. Jouve, M. Blot-Chabaud, N. Bardin, P. Paul, L. Lyonnet, E. Vivier, F. Dignat-George, F. Vely, Mouse CD146/MCAM is a marker of natural killer cell maturation, *Eur. J. Immunol.* 38 (2008) 2855–2864.
- [107] A. Schrage, C. Loddenkemper, U. Erben, U. Lauer, G. Hausdorf, P.R. Jungblut, J. Johnson, P.A. Knolle, M. Zeitz, A. Hamann, K. Klugewitz, Murine CD146 is widely expressed on endothelial cells and is recognized by the monoclonal antibody ME-9F1, *Histochem. Cell Biol.* 129 (2008) 441–451.
- [108] F. Anfosso, N. Bardin, V. Frances, E. Vivier, L. Camoin-Jau, J. Sampol, F. Dignat-George, Activation of human endothelial cells via S-endo-1 antigen (CD146) stimulates the tyrosine phosphorylation of focal adhesion kinase p125/FAK, *J. Biol. Chem.* 273 (1998) 26852–26856.
- [109] F. Anfosso, N. Bardin, E. Vivier, F. Sabatier, J. Sampol, F. Dignat-George, Outside-in signaling pathway linked to CD146 engagement in human endothelial cells, *J. Biol. Chem.* 276 (2001) 1564–1569.
- [110] G. Li, J. Kalabis, X. Xu, F. Meier, M. Oka, T. Bogenrieder, M. Herlyn, Reciprocal regulation of MelCAM and AKT in human melanoma, *Oncogene* 22 (2003) 6891–6899.
- [111] M. Zigler, G.J. Villares, A.S. Dobroff, H. Wang, L. Huang, R.R. Brauer, T. Kamiya, V.O. Melnikova, R. Song, R. Friedman, R.M. Alani, M. Bar-Eli, Expression of Id-1 is regulated by MCAM/MUC18: a missing link in melanoma progression, *Cancer Res.* 71 (2011) 3494–3504.
- [112] X. Yan, Y. Lin, D. Yang, Y. Shen, M. Yuan, Z. Zhang, P. Li, H. Xia, L. Li, D. Luo, Q. Liu, K. Mann, B.L. Bader, A novel anti-CD146 monoclonal antibody, AA98, inhibits angiogenesis and tumor growth, *Blood* 102 (2003) 184–191.
- [113] Q. Zeng, W. Li, D. Lu, Z. Wu, H. Duan, Y. Luo, J. Feng, D. Yang, L. Fu, X. Yan, CD146, an epithelial-mesenchymal transition inducer, is associated with triple-negative breast cancer, *Proc. Natl. Acad. Sci. USA* 109 (2012) 1127–1132.
- [114] Y. Luo, C. Zheng, J. Zhang, D. Lu, J. Zhuang, S. Xing, J. Feng, D. Yang, X. Yan, Recognition of CD146 as an ERM-binding protein offers novel mechanisms for melanoma cell migration, *Oncogene* 31 (2012) 306–321.
- [115] T. Jiang, J. Zhuang, H. Duan, Y. Luo, Q. Zeng, K. Fan, H. Yan, D. Lu, Z. Ye, J. Hao, J. Feng, D. Yang, X. Yan, CD146 is a co-receptor for VEGFR-2 in tumor angiogenesis, *Blood* (2012).
- [116] P. Bu, J. Zhuang, J. Feng, D. Yang, X. Shen, X. Yan, Visualization of CD146 dimerization and its regulation in living cells, *Biochim. Biophys. Acta* 1773 (2007) 513–520.
- [117] J. Zhuang, T. Jiang, D. Lu, Y. Luo, C. Zheng, J. Feng, D. Yang, C. Chen, X. Yan, NADPH oxidase 4 mediates reactive oxygen species induction of CD146 dimerization in VEGF signal transduction, *Free Radic. Biol. Med.* 49 (2010) 227–236.
- [118] J.H. So, S.K. Hong, H.T. Kim, S.H. Jung, M.S. Lee, J.H. Choi, Y.K. Bae, T. Kudoh, J.H. Kim, C.H. Kim, Gicerin/Cd146 is involved in zebrafish cardiovascular development and tumor angiogenesis, *Genes Cells* 15 (2010) 1099–1110.
- [119] N. Murukesh, C. Dive, G.C. Jayson, Biomarkers of angiogenesis and their role in the development of VEGF inhibitors, *Br. J. Cancer* 102 (2010) 8–18.
- [120] A. Kraus, L. Masat, J.P. Johnson, Analysis of the expression of intercellular adhesion molecule-1 and MUC18 on benign and malignant melanocytic lesions using monoclonal antibodies directed against distinct epitopes and recognizing denatured, non-glycosylated antigen, *Melanoma Res.* 7 (Suppl 2) (1997) S75–81.
- [121] B. Song, J.W. Tang, B. Wang, X.N. Cui, C.H. Zhou, L. Hou, Screening for lymphatic metastasis-associated genes in mouse hepatocarcinoma cell lines Hca-F and Hca-P using gene chip, *Ai Zhong* 24 (2005) 774–780.
- [122] G. Zeng, S. Cai, Y. Liu, G.J. Wu, METCAM/MUC18 augments migration, invasion, and tumorigenicity of human breast cancer SK-BR-3 cells, *Gene* 492 (2012) 229–238.
- [123] M.J. Mendez, L.L. Green, J.R. Corvalan, Functional transplant of megabase human immunoglobulin loci recapitulates human antibody response in mice, *Nat. Genet.* 15 (1997) 146–150.
- [124] P. Bu, L. Gao, J. Zhuang, J. Feng, D. Yang, X. Yan, Anti-CD146 monoclonal antibody AA98 inhibits angiogenesis via suppression of nuclear factor-kappaB activation, *Mol. Cancer Ther.* 5 (2006) 2872–2878.
- [125] X. Huang, J. Zhuang, D. Chen, H. Liu, F. Tang, X. Yan, X. Meng, L. Zhang, J. Ren, General strategy for designing functionalized magnetic microspheres for different bioapplications, *Langmuir* 25 (2009) 11657–11663.
- [126] Y. Lin, X. Wu, Y. Shen, P. Bu, D. Yang, X. Yan, A novel antibody AA98 V(H)/L directed against CD146 efficiently inhibits angiogenesis, *Anticancer Res.* 27 (2007) 4219–4224.
- [127] Y. Zhang, C. Zheng, J. Zhang, D. Yang, J. Feng, D. Lu, X. Yan, Generation and characterization of a panel of monoclonal antibodies against distinct epitopes of human CD146, *Hybridoma (Larchmt)* 27 (2008) 345–352.
- [128] C. Zheng, Y. Qiu, Q. Zeng, Y. Zhang, D. Lu, D. Yang, J. Feng, X. Yan, Endothelial CD146 is required for in vitro tumor-induced angiogenesis: the role of a disulfide bond in signaling and dimerization, *Int. J. Biochem. Cell Biol.* 41 (2009) 2163–2172.
- [129] M.C. Leslie, Y.J. Zhao, L.B. Lachman, P. Hwu, G.J. Wu, M. Bar-Eli, Immunization against MUC18/MCAM, a novel antigen that drives melanoma invasion and metastasis, *Gene Ther.* 14 (2007) 316–323.
- [130] S. Bidlingmaier, J. He, Y. Wang, F. An, J. Feng, D. Barbone, D. Gao, B. Franc, V.C. Broaddus, B. Liu, Identification of MCAM/CD146 as the target antigen of a human monoclonal antibody that recognizes both epithelioid and sarcomatoid types of mesothelioma, *Cancer Res.* 69 (2009) 1570–1577.
- [131] H. Schlagbauer-Wadl, B. Jansen, M. Muller, P. Polterauer, K. Wolff, H.G. Eichler, H. Pehamberger, E. Konak, J.P. Johnson, Influence of MUC18/MCAM/CD146 expression on human melanoma growth and metastasis in SCID mice, *Int. J. Cancer* 81 (1999) 951–955.
- [132] J. Beutel, J. Wegner, R. Wegner, F. Ziemssen, K. Nassar, J.M. Rohrbach, R.D. Hilgers, M. Luke, S. Grisanti, Possible implications of MCAM expression in metastasis and non-metastatic of primary uveal melanoma patients, *Curr. Eye Res.* 34 (2009) 1004–1009.
- [133] K. Satyamoorthy, J. Muylers, F. Meier, D. Patel, M. Herlyn, Mel-CAM-specific genetic suppressor elements inhibit melanoma growth and invasion through loss of gap junctional communication, *Oncogene* 20 (2001) 4676–4684.
- [134] K. Watson-Hurst, D. Becker, The role of N-cadherin, MCAM and beta3 integrin in melanoma progression, proliferation, migration and invasion, *Cancer Biol. Ther.* 5 (2006) 1375–1382.
- [135] G. Feng, F. Fang, C. Liu, F. Zhang, H. Huang, C. Pu, CD146 gene expression in clear cell renal cell carcinoma: a potential marker for prediction of early recurrence after nephrectomy, *Int. Urol. Nephrol.* (25) (2012) [Epub ahead of print].
- [136] W.F. Liu, S.R. Ji, J.J. Sun, Y. Zhang, Z.Y. Liu, A.B. Liang, H.Z. Zeng, CD146 Expression Correlates with Epithelial-Mesenchymal Transition Markers and a Poor Prognosis in Gastric Cancer, *Int. J. Mol. Sci.* 13 (2012) 6399–6406.
- [137] S. Oka, H. Uramoto, Y. Chikaishi, F. Tanaka, The expression of CD146 predicts a poor overall survival in patients with adenocarcinoma of the lung, *Anticancer Res.* 32 (2012) 861–864.
- [138] W. Wang, Z.L. Yang, J.Q. Liu, S. Jiang, X.Y. Miao, Identification of CD146 expression, angiogenesis, and lymphangiogenesis as progression, metastasis, and poor-prognosis related markers for gallbladder adenocarcinoma, *Tumour Biol.* 33 (2012) 173–182.
- [139] A. Sato, I. Torii, Y. Okamura, T. Yamamoto, T. Nishigami, T.R. Kataoka, M. Song, S. Hasegawa, T. Nakano, T. Kamei, T. Tsujimura, Immunocytochemistry of CD146 is useful to discriminate between malignant pleural mesothelioma and reactive mesothelium, *Mod. Pathol.* 23 (2010) 1458–1466.
- [140] W. Chen, H.L. Zhang, Y.G. Jiang, J.H. Li, B.L. Liu, M.Y. Sun, Inhibition of CD146 gene expression via RNA interference reduces in vitro perineural invasion on ACC-M cell, *J. Oral Pathol. Med.* 38 (2009) 198–205.
- [141] W. Li, D. Yang, S. Wang, X. Guo, R. Lang, Y. Fan, F. Gu, X. Zhang, Y. Niu, X. Yan, L. Fu, Increased expression of CD146 and microvessel density (MVD) in invasive micropapillary carcinoma of the breast: Comparative study with invasive ductal carcinoma-not otherwise specified, *Pathol. Res. Pract.* 207 (2011) 739–746.
- [142] G. Zabouo, A.M. Imbert, J. Jacquemier, P. Finetti, T. Moreau, B. Esterni, D. Birnbaum, F. Bertucci, C. Chabannon, CD146 expression is associated with a poor prognosis in human breast tumors and with enhanced motility in breast cancer cell lines, *Breast Cancer Res.* 11 (2009) R1.
- [143] S. Garcia, J.P. Dales, E. Charafe-Jauffret, S. Carpentier-Meunier, L. Andrac-Meyer, J. Jacquemier, C. Andonian, M.N. Lavaut, C. Allasia, P. Bonnier, C. Charpin, Poor prognosis in breast carcinomas correlates with increased

- 1208 expression of targetable CD146 and c-Met and with proteomic basal-like
1209 phenotype, *Hum. Pathol.* 38 (2007) 830–841.
- [144] Q. Li, Y. Yu, J. Bischoff, J.B. Mulliken, B.R. Olsen, Differential expression of
1210 CD146 in tissues and endothelial cells derived from infantile haemangioma
1211 and normal human skin, *J. Pathol.* 201 (2003) 296–302.
- [145] G. Kristiansen, Y. Yu, K. Schluns, C. Sers, M. Dietel, I. Petersen, Expression of
1212 the cell adhesion molecule CD146/MCAM in non-small cell lung cancer, *Anal.
1213 Cell. Pathol.* 25 (2003) 77–81.
- [146] F.R. Pires, M. Shih le, D.E. da Cruz Perez, O.P. de Almeida, L.P. Kowalski, Mel-
1214 CAM (CD146) expression in parotid mucoepidermoid carcinoma, *Oral Oncol.*
1215 39 (2003) 277–281.
- [147] F.R. Fritzsche, K. Wassermann, A. Rabien, H. Schick Tanz, A. Dankof, S.A.
1216 Loening, M. Dietel, K. Jung, G. Kristiansen, CD146 protein in prostate cancer:
1217 revisited with two different antibodies, *Pathology* 40 (2008) 457–464.
- [148] G.J. Wu, V.A. Varma, M.W. Wu, S.W. Wang, P. Qu, H. Yang, J.A. Petros, S.D. Lim,
1218 M.B. Amin, Expression of a human cell adhesion molecule, MUC18, in
1219 prostate cancer cell lines and tissues, *Prostate* 48 (2001) 305–315.
- [149] G.J. Wu, M.W. Wu, S.W. Wang, Z. Liu, P. Qu, Q. Peng, H. Yang, V.A. Varma, Q.C.
1220 Sun, J.A. Petros, S.D. Lim, M.B. Amin, Isolation and characterization of the
1221 major form of human MUC18 cDNA gene and correlation of MUC18 over-
1222 expression in prostate cancer cell lines and tissues with malignant
1223 progression, *Gene* 279 (2001) 17–31.
- [150] I.M. Shih, T.L. Wang, W.H. Westra, Diagnostic and biological implications of
1224 mel-CAM expression in mesenchymal neoplasms, *Clin. Cancer Res.* 2 (1996)
1225 569–575.
- [151] R.J. Filshie, A.C. Zannettino, V. Makrynika, S. Gronthos, A.J. Henniker, L.J.
1226 Bendall, D.J. Gottlieb, P.J. Simmons, K.F. Bradstock, MUC18, a member of the
1227 immunoglobulin superfamily, is expressed on bone marrow fibroblasts and
1228 a subset of hematological malignancies, *Leukemia* 12 (1998) 414–421.
- [152] M. Pardo, A. Garcia, B. Thomas, A. Pineiro, A. Akoulitchev, R.A. Dwek, N.
1229 Zitzmann, The characterization of the invasion phenotype of uveal melanoma
1230 tumour cells shows the presence of MUC18 and HMG-1 metastasis markers
1231 and leads to the identification of DJ-1 as a potential serum biomarker, *Int. J.
1232 Cancer* 119 (2006) 1014–1022.
- [153] G.F. Zeng, S.X. Cai, G.J. Wu, Up-regulation of METCAM/MUC18 promotes
1233 motility, invasion, and tumorigenesis of human breast cancer cells, *BMC
1234 Cancer* 11 (2011) 113.
- [154] C. Schiano, V. Grimaldi, A. Casamassimi, T. Infante, A. Esposito, A. Giovane, C.
1235 Napoli, Different expression of CD146 in human normal and osteosarcoma
1236 cell lines, *Med. Oncol.* (2012).
- [155] G.J. Wu, Q. Peng, P. Fu, S.W. Wang, C.F. Chiang, D.L. Dillehay, M.W. Wu,
1237 Ectopical expression of human MUC18 increases metastasis of human
1238 prostate cancer cells, *Gene* 327 (2004) 201–213.
- [156] Z. Wu, Z. Wu, J. Li, X. Yang, Y. Wang, Y. Yu, J. Ye, C. Xu, W. Qin, Z. Zhang, MCAM
1239 is a novel metastasis marker and regulates spreading, apoptosis and invasion
1240 of ovarian cancer cells, *Tumour Biol.* (2012).
- [157] G.J. Wu, P. Fu, C.F. Chiang, W.J. Huss, N.M. Greenberg, M.W. Wu, Increased
1241 expression of MUC18 correlates with the metastatic progression of mouse
1242 prostate adenocarcinoma in the TRAMP model, *J. Urol.* 173 (2005) 1778–
1243 1783.
- [158] G.J. Wu, P. Fu, S.W. Wang, M.W. Wu, Enforced expression of MCAM/MUC18
1244 increases in vitro motility and invasiveness and in vivo metastasis of two
1245 mouse melanoma K1735 sublines in a syngeneic mouse model, *Mol. Cancer
1246 Res.* 6 (2008) 1666–1677.
- [159] K. Adachi, M. Hattori, H. Kato, M. Inai, M. Tsukamoto, E. Handharyani, E. Taira,
1247 Y. Tsukamoto, Involvement of gicerin, a cell adhesion molecule, in the portal
1248 metastasis of rat colorectal adenocarcinoma cells, *Oncol. Rep.* 24 (2010)
1249 1427–1431.
- [160] Y. Tsukamoto, T. Sakaiuchi, S. Hiroi, M. Furuya, S. Tsuchiya, F. Sasaki, N. Miki,
1250 E. Taira, Expression of gicerin enhances the invasive and metastatic activities
1251 of a mouse mammary carcinoma cell line, *Int. J. Oncol.* 23 (2003) 1671–1677.
- [161] S. Tsuchiya, Y. Tsukamoto, M. Furuya, S. Hiroi, N. Miki, F. Sasaki, E. Taira,
1252 Gicerin, a cell adhesion molecule, promotes the metastasis of lymphoma cells
1253 of the chicken, *Cell Tissue Res.* 314 (2003) 389–397.

UNCORRECTED PROOF